

GENERAL NOTES

- DRAWINGS ARE TO BE READ IN CONJUNCTION WITH ALL RELEVANT SPECIFICATIONS, ENGINEERS, ARCHITECTS & SERVICES DRAWINGS, INCLUDING APPROVED BUILDERS WORK DRAWINGS. CONTRACTOR TO NOTIFY ENGINEER OF DISCREPANCIES BETWEEN STRUCTURAL DRAWINGS AND SPECIFICATIONS OR OTHER DRAWINGS.
- ALL DIMENSIONS ARE IN MILLIMETRES UNLESS NOTED OTHERWISE.
- DO NOT SCALE FROM THE DRAWINGS OR THE COMPUTER DIGITAL DATA, ONLY FIGURED DIMENSIONS ARE TO BE USED.
- THE CONTRACTOR SHALL BE RESPONSIBLE FOR THE DESIGN, FABRICATION, ERECTION AND REMOVAL OF ALL TEMPORARY WORKS AND SHALL PROVIDE ALL TEMPORARY BRACING AS NECESSARY TO MAINTAIN STRUCTURAL STABILITY DURING CONSTRUCTION.
- IF THE CONTRACTOR CONSIDERS THAT HE DOES NOT HAVE SUFFICIENT INFORMATION TO SAFELY COMPLETE THE WORKS DETAILED ON THIS DRAWING, HE SHOULD CONTACT THE ENGINEER.

NOTE:

ALL STEELWORK IS TO BE HOT DIPPED GALVANISED AND THEN PAINTED. COLOUR TO BE AGREED.

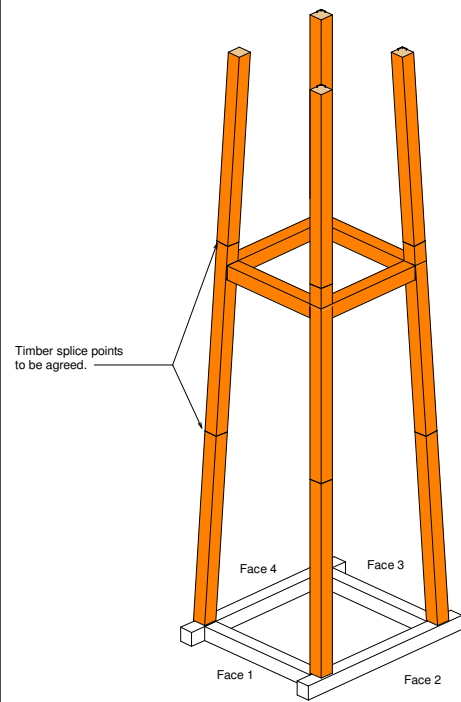

(1) Construct Timber Tower

1 3D View 1

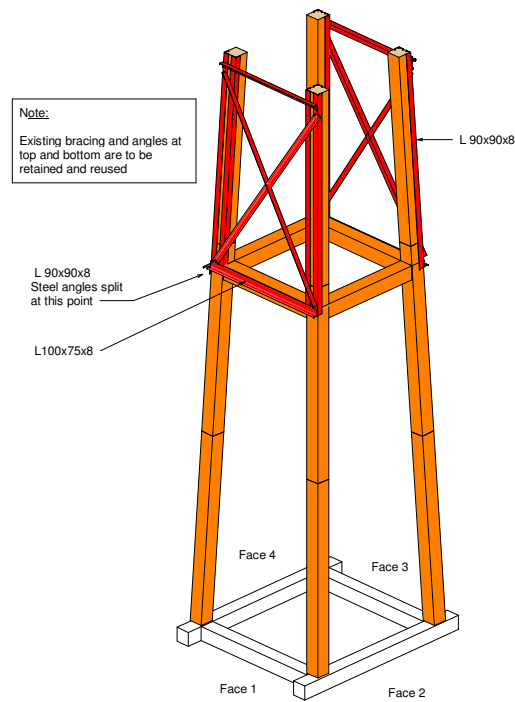

(2) Offer Up Faces 1 and 3

2 3D View 2

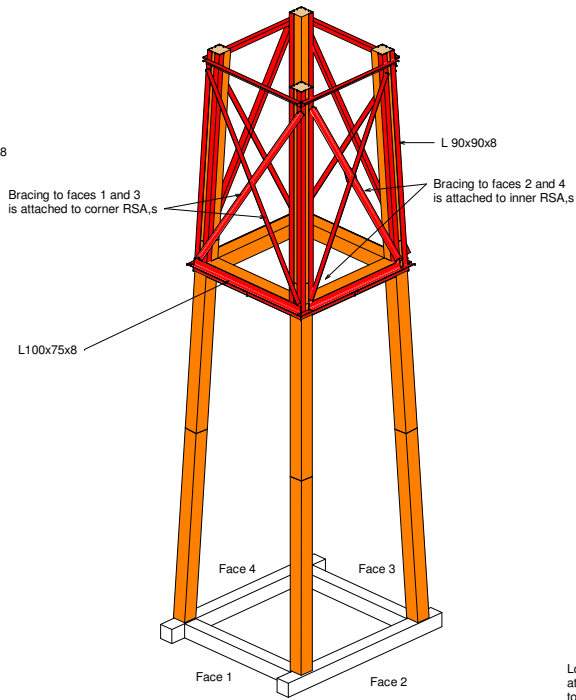

(3) Offer up Face 2 and 4

3 3D View 3

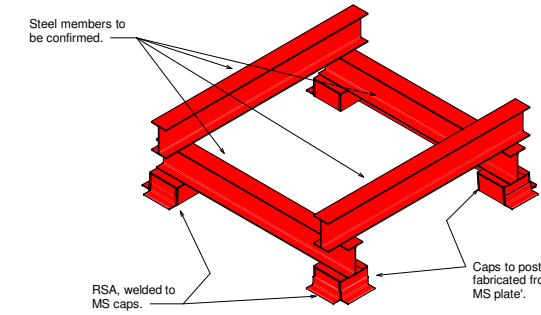

Enlarged View At Top Of Tower

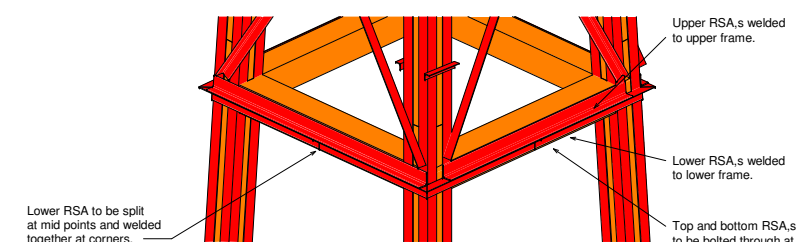

Enlarged Views At Level Of Steel Split

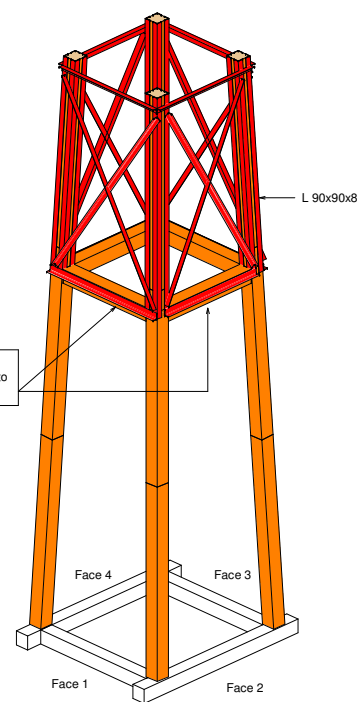

(4) Internal R.S.A.s To Top Section

4 3D View 4

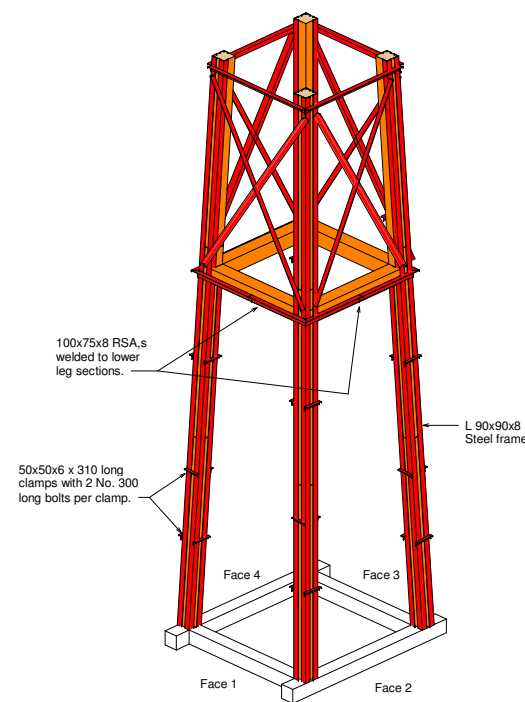

(5) Bring In Lower Level Steelwork

6 3D View 5

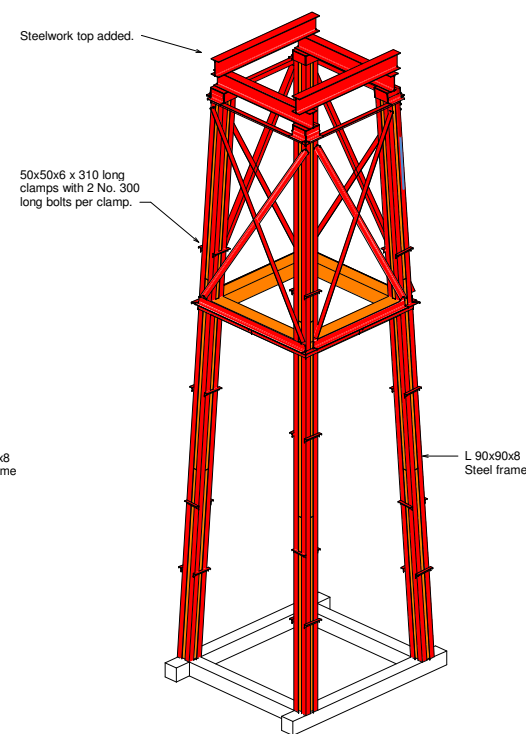

(6) Complete Steelwork

8 3D View 6

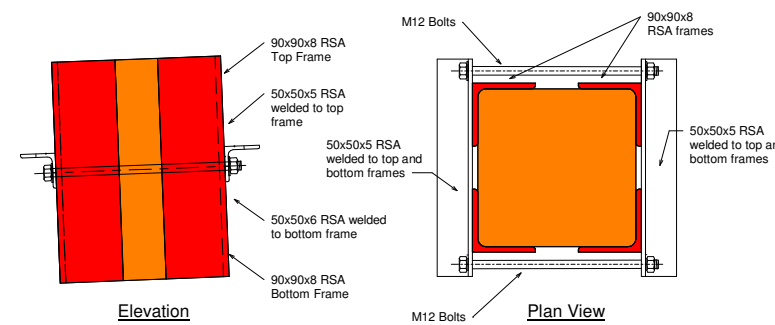

Frame Clamping Detail

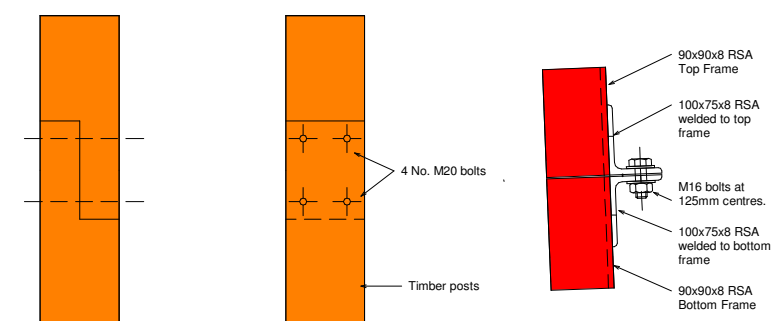

Timber Half Lap Joint

Fastening Detail For Top to Bottom Frames

P3	FOR INFORMATION. NOTE AMENDED	SPH	23.08.19	JE
P2	FOR INFORMATION	SPH	22.08.19	JE
P1	FOR INFORMATION	SPH	15.08.19	JE
Rev	Description	Drawn	Date	Chk



MURGATROYDS BRINE PUMP

Reconstruction Of Gantry Outline Order Of Work

Project Status				
Information				
Drawing No. 8903 - 001				Revision P3
Scale NTS	Size A1	Drawn SPH	Date Aug 19	Chkd JE
Passed				